



AMERICAN
CONTROL
ELECTRONICS

RGA Series

USER MANUAL

RGA400-3
RGA400-10
RGA403-3
RGA403-10
RGA440-3
RGA440-10

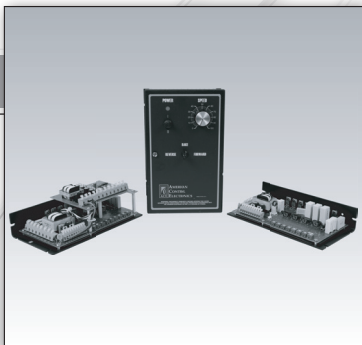

Dear Valued Consumer:

Congratulations on your purchase of the **RGA Series** drive. This User Manual was created for you to get the most out of your new device and assist with the initial setup. Please visit www.americancontrolelectronics.com to learn more about our other drives.

Thank you for choosing **American Control Electronics!**

© 2012 American Control Electronics®. All rights reserved.

No part of this manual may be reproduced or transmitted in any form without written permission from American Control Electronics®. The information and technical data in this document are subject to change without notice. American Control Electronics® and its divisions make no warranty of any kind with respect to this material, including, but not limited to, the implied warranties of its merchantability and fitness for a given purpose. American Control Electronics® and its divisions assume no responsibility for any errors that may appear in this manual and make no commitment to update or to keep current the information in this manual.

Safety First!

SAFETY WARNINGS



Text in gray boxes denote important safety tips or warnings. Please read these instructions carefully before performing any of the procedures contained in this manual.

- **DO NOT INSTALL, REMOVE, OR REWIRE THIS EQUIPMENT WITH POWER APPLIED.** Have a qualified electrical technician install, adjust and service this equipment. Follow the National Electrical Code and all other applicable electrical and safety codes, including the provisions of the Occupational Safety and Health Act (OSHA), when installing equipment.
- Reduce the chance of an electrical fire, shock, or explosion by using proper grounding techniques, over-current protection, thermal protection, and enclosure. Follow sound maintenance procedures.



It is possible for a drive to run at full speed as a result of a component failure. AMERICAN CONTROL ELECTRONICS® (ACE) strongly recommends the installation of a master switch in the main power input to stop the drive in an emergency.

Circuit potentials are at 115 VAC or 230 VAC above earth ground. Avoid direct contact with the printed circuit board or with circuit elements to prevent the risk of serious injury or fatality. Use a non-metallic screwdriver for adjusting the calibration trim pots. Use approved personal protection equipment and insulated tools if working on this drive with power applied.

Table of Contents

Section 1. Regenerative Drives	1
Section 2. Specifications	2
Section 3. Dimensions.....	4
Section 4. Installation.....	8
Chassis Drives	8
Mounting	8
Heat Sinking.....	9
Speed Adjust Potentiometer	10
Wiring	11
Shielding Guidelines	11
Line Fusing.....	12
Connections	14
Cased Drives	23
Mounting (NEMA 4X Enclosures).....	23
Wiring	24
Line Fusing.....	24
Connections	25
Section 5. Operation.....	27
Before Applying Power	27
Select Switches	28
Input Voltage Select (SW501)	28
Armature Voltage Select (SW502)	28
Feedback Select (SW504)	28
Signal Select (SW501) (RG403 models only).....	29
Input Voltage Select (SW502) (RG403 models only)	29
Startup	30
RG400-3, RG400-10, RG403-3, RG403-10.....	30
RG440-3 and RG440-10	31
Starting and Stopping Methods	32
Line Starting and Stopping	32
Regenerative Braking to Zero Speed (INHIBIT Terminals)	33
Regenerative Decel to Zero Speed (RB1 and RB2 Terminals) ...	34

Regenerative Decel to Minimum Speed	35
Coast to Zero Speed (INHIBIT-RUN)	36
Section 6. Calibration	37
Minimum Speed (MIN SPD)	38
Maximum Speed (MAX SPD)	38
Forward Torque (FWD TQ)	39
Reverse Torque (REV TQ)	40
IR Compensation (IR COMP)	41
Forward Acceleration (FWD ACC)	43
Reverse Acceleration (REV ACC)	43
Deadband (DB)	44
Tachogenerator (TACH)	45
Minimum Out (MIN OUT) (RG403 models only)	46
Maximum Out (MAX OUT) (RG403 models only)	46
Signal Input Adjust (SIGNAL INPUT ADJUST) (RG403 models only)	46
Section 7. Application Notes	48
FWD-REV and FWD-STOP-REV Switch	48
Multiple Fixed Speeds	49
Adjustable Speeds using Potentiometers in Series	50
Independent Adjustable Speeds	51
Independent Forward and Reverse Speeds	52
FWD-REV Switch with End-of-Travel Limit Switches	53
RUN/JOG Switch - Inhibit Connection	54
RUN/JOG Switch - Potentiometer Connection	55
Leader-Follower Application	56
Section 8. Troubleshooting	57
Before Troubleshooting	57
Section 9. Block Diagrams	60
Section 10. Accessories & Replacement Parts	61
Notes	62
Unconditional Warranty	63

List of Tables

Table 1	Recommended Line Fuse Sizes	13
Table 2	Field Output Connections	16

List of Figures

Figure 1	Four Quadrant Operation	1
Figure 2	RG400-3 and RG400-10 Dimensions	4
Figure 3	RG403-3 and RG403-10 Dimensions	5
Figure 4	RG440-3 and RG440-10 Dimensions	6
Figure 5	HSK-0004 Dimensions.....	7
Figure 6	Speed Adjust Potentiometer	10
Figure 7	Cage Clamp Terminal Block	14
Figure 8(a)	Unidirectional Forward.....	17
Figure 8(b)	Unidirectional Reverse	17
Figure 8(c)	Bidirectional	17
Figure 9	Chassis Drive Connections	19
Figure 10	RG400 and RG440 Analog Input Signal Connections	20
Figure 11	RG403 Connections	22
Figure 12	Cased Drive Connections	26
Figure 13	Select Switches	28
Figure 14	SW501 Settings	29
Figure 15	RG403 Select Switches.....	29
Figure 16	Inhibit Terminals	33
Figure 17	Run/Decelerate to Minimum Speed Switch	35
Figure 18	Inhibit-Run Terminal Location and Run/Coast Switch	36
Figure 19	Recommended TORQUE and IR COMP Settings	42
Figure 20	DIP Switch SW501 Settings	46
Figure 21	Forward-Reverse Switch	48
Figure 22	Forward-Stop-Reverse Switch	48
Figure 23	Multiple Fixed Speeds	49
Figure 24	Adjustable Speeds using Potentiometers in Series	50
Figure 25	Independent Adjustable Speeds.....	51
Figure 26	Independent Adjustable Forward and Reverse Speeds.....	52

Figure 27	Independent Adjustable Forward and Reverse Speeds with Stop.....	52
Figure 28	FWD-REV Switch withh End-of-Travel Limit Switches.....	53
Figure 29	RUN/JOG Switch - Inhibit Connection.....	54
Figure 30	RUN/JOG Switch - Potentiometer Connection.....	55
Figure 31	Leader-Follower Application.....	56
Figure 32	Prewired Connections for RGA440.....	60

Section 1. Regenerative Drives

Most non-regenerative, variable speed, DC drives control current flow to a motor in one direction. The direction of current flow is the same direction as the motor rotation. Non-regenerative drives operate in Quadrant I, and also in Quadrant III if the drive is reversible (see Figure 1). Motors must stop before reversing direction. Unless dynamic braking is used, non regenerative drives cannot decelerate a load faster than coasting to a lower speed.

Regenerative drives operate in two additional quadrants: Quadrant II and Quadrant IV. In these quadrants, motor torque is in the opposite direction of motor rotation.

This allows regenerative drives to reverse a motor without contractors or switches, to control an overhauling load, and to decelerate a load faster than it would coast to a lower speed.

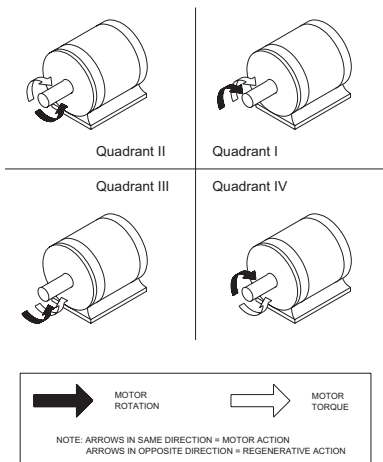

Figure 1. Four Quadrant Operation

Section 2. Specifications

<i>Model</i>	<i>Maximum Armature Current (ADC)</i>	<i>HP Range with 90 VDC Motor</i>	<i>HP Range with 180 VDC Motor</i>	<i>Enclosure</i>
RGA400-3	3.0	1/20 - 1/8	1/10 - 1/4	Chassis
RGA403-3				Chassis
RGA440-3				NEMA 4X
RGA400-10*	10.0	1/8 - 1/2	1/4 - 1	Chassis
RGA403-10*				Chassis
RGA440-10				NEMA 4X

* Heat sink kit part number HSK-0004 must be used when the continuous current output is over 7 amps.

AC Line Voltage 115/230 VAC \pm 10%
50/60 Hz, single phase

DC Armature Voltage
with 115 VAC Line Voltage 0 - 90 VDC
with 230 VAC Line Voltage 0 - 180 VDC

Field Voltage
with 115 VAC Line Voltage 50 VDC (F1 to L1)
100 VDC (F1 to F2)
with 230 VAC Line Voltage 100 VDC (F1 to L1)
200 VDC (F1 to F2)

Maximum Field Current 1 ADC

Acceleration Time Range 0.5 - 15 seconds

Deceleration Time Range 0.5 - 15 seconds

Analog Input Range

RGA400 and RGA440 models (Signal must be isolated; RB1 to S2)

Voltage Signal Range 0 to \pm 10 VDC

RGA403 model (Signal may be isolated or non-isolated; COM to INPUT 1 or INPUT 2)

Voltage Signal Range (Narrow) 0 to \pm 10 VDC

Voltage Signal Range (Wide) 0 to \pm 250 VDC

Current Signal Range 1 - 5, 4 - 20, 10 - 50 mA

Input Impedance

<i>RGA400 and RGA440 models (RB1 to S2)</i>	32K ohms
<i>RGA403 models (Voltage Signal)</i>	>25K ohms
<i>RGA403 models (1-5 mA Signal)</i>	1K ohms
<i>RGA403 models (4-20 mA Signal)</i>	235 ohms
<i>RGA403 models (10-50 mA Signal)</i>	100 ohms

Form Factor

1.37 at base speed

Load Regulation

1% base speed or better

with 115 VAC Line Voltage
with 230 VAC Line Voltage

Vibration

0.5G maximum (0 - 50 Hz)

0.1G maximum (> 50 Hz)

Safety Certification

UL Recognized Component, File # E132235

CSA Certified Component, File # LR41380

Ambient Temperature Range*Chassis Drive* 10°C - 55°C*Cased Drive* 10°C - 40°C

Section 3. Dimensions

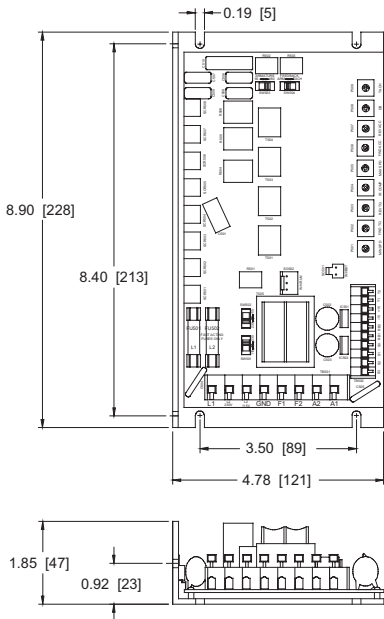

ALL DIMENSIONS IN INCHES [MILLIMETERS]

Figure 2. RGA400-3 and RGA400-10 Dimensions

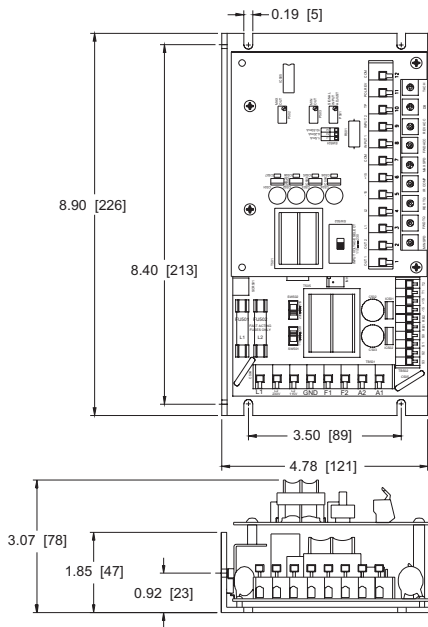

ALL DIMENSIONS IN INCHES [MILLIMETERS]

Figure 3. RGA403-3 and LGC403-10 Dimensions

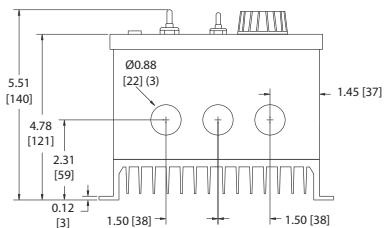
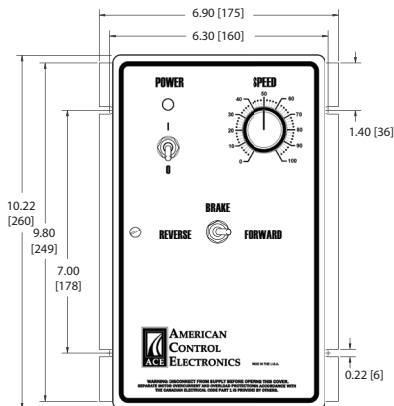

ALL DIMENSIONS IN INCHES [MILLIMETERS]

Figure 4. RGA440-3 and RGA440-10 Dimensions

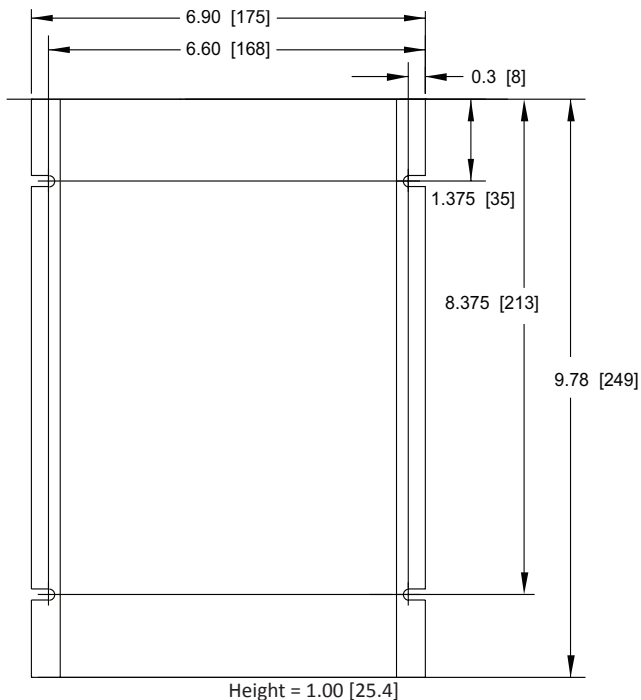

ALL DIMENSIONS IN INCHES [MILLIMETERS]

Figure 5. HSK-0004 Dimensions

Section 4. Installation



Do not install, rewire, or remove this control with input power applied. Failure to heed this warning may result in fire, explosion, or serious injury. Make sure you read and understand the Safety Precautions on page i before attempting to install this product.

Chassis Drives

Mounting

- Drive components are sensitive to electrostatic discharge. Avoid direct contact with the circuit board. Hold the drive by the chassis or heat sink only.
- Protect the drive from dirt, moisture, and accidental contact.
- Provide sufficient room for access to the terminals and calibration trim pots.
- Mount the drive away from heat sources. Operate the drive within the specified ambient operating temperature range.
- Prevent loose connections by avoiding excessive vibration of the drive.
- Mount the drive with its board in either a horizontal or vertical plane. Six 0.19" (5 mm) wide slots in the chassis accept #8 pan head screws. Fasten either the large base or the narrow flange of the chassis to the subplate.
- The chassis should be earth grounded. Use a star washer beneath the head of at least one of the mounting screws to penetrate the anodized surface and to reach bare metal.

Heat Sinking

The RGA series drives RGA400-10 and RGA403-10 require an additional heat sink when the continuous armature current is above 7 ADC. Use ACE heat sink kit part number HSK-0004. All other chassis drives have sufficient heat sinking in their basic configuration. Use a thermally conductive heat sink compound (such as Dow Corning® 340 Heat Sink Compound) between the chassis and the heat sink surface for optimum heat transfer.

Speed Adjust Potentiometer



Be sure that the potentiometer tabs do not make contact with the potentiometer's body. Grounding the input will cause damage to the drive.

Mount the speed adjust potentiometer through a 0.38 in. (10 mm) hole with the hardware provided (Figure 6). Install the circular insulating disk between the panel and the 10K ohm speed adjust potentiometer.

Twist the speed adjust potentiometer wires to avoid picking up unwanted electrical noise. If the speed adjust potentiometer wires are longer than 18 in. (46 cm), use shielded cable. Keep the speed adjust potentiometer wires separate from power leads (L1, L2 115V, L2 230V, A1, A2, F1, F2).

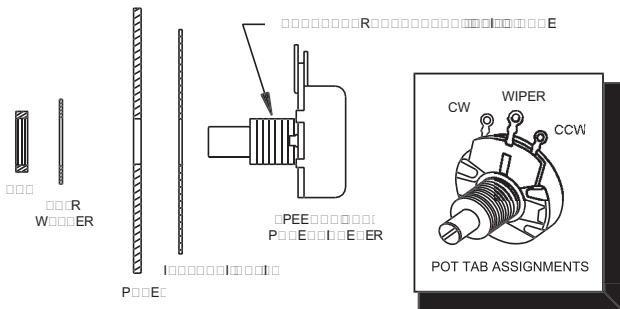

Figure 6. Speed Adjust Potentiometer

Wiring



Do not install, rewire, or remove this control with input power applied. Failure to heed this warning may result in fire, explosion, or serious injury.

Circuit potentials are at 115 or 230 VAC above ground. To prevent the risk of injury or fatality, avoid direct contact with the printed circuit board or with circuit elements.

Do not disconnect any of the motor leads from the drive unless power is removed or the drive is disabled. Opening any one motor lead while the drive is running may destroy the drive.

- Use 18 - 24 AWG wire for logic wiring. Use 14 - 16 AWG wire for AC line and motor wiring.

Shielding Guidelines



Under no circumstances should power and logic level leads be bundled together. Induced voltage can cause unpredictable behavior in any electronic device, including motor controls.

As a general rule, AMERICAN CONTROL ELECTRONICS® (ACE) recommends shielding of all conductors. If it is not practical to shield power conductors, ACE recommends shielding all logic-level leads. If shielding of all logic-level leads is not practical, the user should twist all logic leads with themselves to minimize induced noise.

It may be necessary to earth ground the shielded cable. If noise is produced by devices other than the drive, ground the shield at the drive end. If noise is generated by a device on the drive, ground the shield at the end away from the drive. Do not ground both ends of the shield.

Shielding Guidelines (continued)

If the drive continues to pick up noise after grounding the shield, it may be necessary to add AC line filtering devices, or to mount the drive in a less noisy environment.

Logic wires from other input devices, such as motion controllers and PLL velocity controllers, must be separated from power lines in the same manner as the logic I/O on this drive.

Line Fusing

All models are preinstalled with two line fuses in fuse holders FU501 and FU502.

Models RGA400-10 and RG403-10 are preinstalled with 20 amp fuses. Models RGA400-3 and RGA403-3 are preinstalled with 8 amp fuses.

Preinstalled line fuses are rated at or close to maximum horsepower. If the horsepower rating of the motor being used is less than the maximum horsepower rating of the drive, the line fuse may have to be replaced with a lower rated one. Fuses should be rated for 250 VAC or higher and approximately 150% of the maximum armature current. Refer to Table 1 on page 13 for recommended fuse values.

Table 1. Recommended Line Fuse Sizes

<i>90 VDC Motor Horsepower</i>	<i>180 VDC Motor Horsepower</i>	<i>Maximum DC Armature Current (amps)</i>	<i>AC Line Fuse Size (amps)</i>
<i>1/20</i>	<i>1/10</i>	<i>0.5</i>	<i>1</i>
<i>1/15</i>	<i>1/8</i>	<i>0.8</i>	<i>1.5</i>
<i>1/8</i>	<i>1/4</i>	<i>1.5</i>	<i>3</i>
<i>1/6</i>	<i>1/3</i>	<i>1.7</i>	<i>3</i>
<i>1/4</i>	<i>1/2</i>	<i>2.5</i>	<i>5</i>
<i>1/3</i>	<i>3/4</i>	<i>3.5</i>	<i>8</i>
<i>1/2</i>	<i>1</i>	<i>5.0</i>	<i>10</i>
<i>3/4</i>	<i>1 ½</i>	<i>7.5</i>	<i>15</i>
<i>1</i>	<i>2</i>	<i>10</i>	<i>20</i>

ACE offers fuse kits. See Section 10: Accessories and Replacement Parts for fuse kit part numbers.

Connections



Do not install, rewire, or remove this control with input power applied. Failure to heed this warning may result in fire, explosion, or serious injury.

ACE strongly recommends the installation of a master power switch in the voltage input line, as shown in Figure 9 (page 19). The switch contacts should be rated at a minimum of 200% of motor nameplate current and 250 volts.

Cage Clamp Terminal Block

RGA series drives use cage-clamp terminal blocks. To connect a wire to the cage-clamp terminal block (see Figure 7), use a small screwdriver to press down on the lever arm. Insert a wire stripped approximately 0.25 inches (6 mm) into the opening in front of the terminal block. Release the lever arm to clamp the wire.

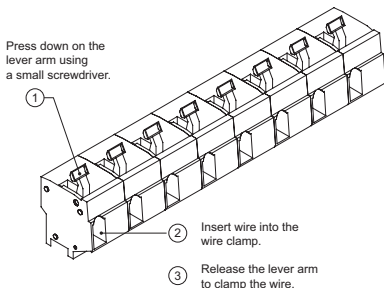

Figure 7. Cage Clamp Terminal Block

Power Input

Connect the AC line power leads to terminals L1 and L2 115V if using 115 VAC line or to terminals L1 and L2 230V is using a 230 VAC line. ACE recommends the use of a single-throw, double-pole master power switch. The switch should be rated at a minimum of 250 volts and 200% of motor current. Refer to Figure 9 on page 19.

Motor

ACE drives supply motor voltage from A1 and A2 terminals, where A1 is positive with respect to A2 in the forward direction. If the motor does not spin in the desired direction, remove power and reverse the A1 and A2 connections.

Connect a DC motor to terminals A1 and A2 as shown in Figure 9 on page 19. Ensure that the motor voltage rating is consistent with the drive's output voltage.

Field Output Connections



The field output is for shunt wound motors only. Do not make any connections to F1 and F2 when using a permanent magnet motor.

See Table 2 for field output connections. Use 14 - 16 AWG wire to connect the field output to a field / shunt wound motor.

Table 2. Field Output Connections

<i>Line Voltage (VAC)</i>	<i>Approximate Field Voltage (VDC)</i>	<i>Connect Motor Field To</i>
115	50	F1 and L1
115	100	F1 and F2
230	100	F1 and L1
230	200	F1 and F2

Speed Adjust Potentiometer

Use a 10K ohm, 1/4 W potentiometer for speed control. The motor can operate in one direction (unidirectional) or two directions (bidirectional) depending on how the speed adjust potentiometer is connected to the drive.

For unidirectional operation in the forward direction, connect the speed adjust potentiometer as shown in Figure 8(a).

For unidirectional operation in the reverse direction, connect the speed adjust potentiometer as shown in Figure 8(b).

For bidirectional operation, connect the speed adjust potentiometer as shown in Figure 8(c). The motor does not operate when the potentiometer is in the center position. Turning the potentiometer clockwise (CW) from the center position causes the motor to rotate in the forward direction, while turning the potentiometer counterclockwise (CCW) causes rotation in the reverse direction.

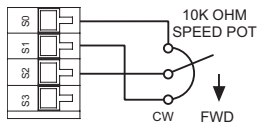

Figure 8(a). Unidirectional Forward

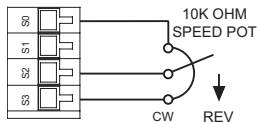

Figure 8(b). Unidirectional Reverse

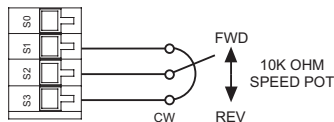

Figure 8(c). Bidirectional

Tachogenerator Feedback

Using tachogenerator feedback improves speed regulation from approximately 1% of motor base speed to approximately 0.1% of motor base speed. Use tachogenerators rated from 7 VDC per 1000 RPM to 50 VDC per 1000 RPM. Connect the tachogenerator to terminals T1 and T2 of terminal block TB502. Place SW504 in the TACH position. See Figure 9 on page 19 for tachogenerator connections. The TACH trim pot must be adjusted prior to operating with tachogenerator feedback. Refer to the Calibration section for instructions on calibrating the TACH trim pot.

+15 and -15



Do not short the +15 and -15 terminals for any reason. Shorting these terminals will damage the drive.

RGA series drives can supply a regulated +15 and -15 VDC signal (each sourcing 15 mA maximum) with respect to RB1 or T1, to isolated, external devices. These voltage supply terminals are located on terminal block TB502.

Enable, Inhibit, and Regen Brake Connections

See the “Starting and Stopping Methods” section on pages 32 through 36 for a detailed description of the Enable, Inhibit, and Regen Braking (RB1, RB2) connections.

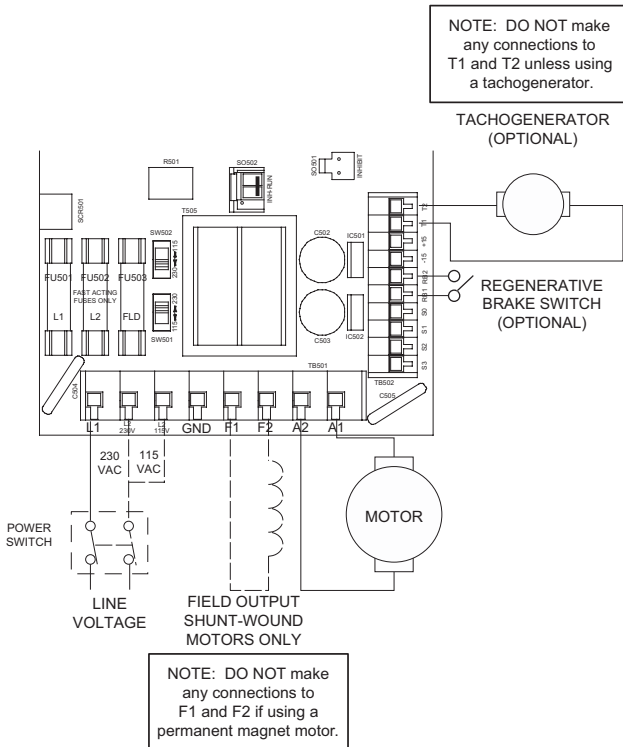

Figure 9. Chassis Drive Connections

Analog Input Signal (RGA400, RG440 models)

Instead of using a speed adjust potentiometer, the drive may be wired to follow an analog input voltage signal that is isolated from earth ground (Figure 10). Connect the signal common (-) to RB1. Connect the signal reference (+) to S2. Make no connection to S0, S1 or S3. A potentiometer can be used to scale the analog input voltage. An interface device, such as ACE model ISO401-1, may be used to scale and isolate an analog input voltage.

An input voltage range of approximately 0 to ± 10 VDC is required to produce an armature voltage range of 0 to ± 90 VDC with a 115 VAC line, or 0 to ± 180 VDC with a 230 VAC line.

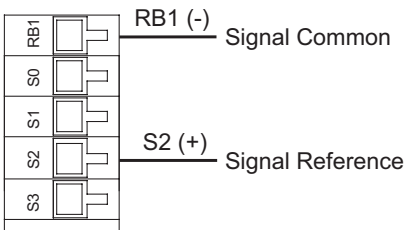

Figure 10. RGA400 and RG440 Analog Input Signal Connections

Analog Input Signal (RGA403 models)

Instead of using a speed adjust potentiometer, the drive may be wired to follow a unipolar or bipolar analog input voltage or a unipolar current signal that is either isolated or non-isolated from earth ground. Connect the signal common (-) to terminal 7 (COM). If using an input current signal or an input voltage signal of 0 to ± 25 VDC or less, connect the signal reference (+) to terminal 8 (INPUT 1), or if using an input voltage signal greater than 0 to ± 25 VDC, connect the signal reference (+) to terminal 9 (INPUT 2). Refer to Figure 11 on page 22.

Refer to Figure 14 on page 29 for Signal Select switch SW501 settings and Figure 15 on page 29 for switch SW501 location.

If using an input current signal, a direction switch must be used to change direction.

Direction Switch (RGA403 models)

A single-pole, single-throw switch can be used as a reversal switch. Connect the switch to terminals COM and POL REV. Close the switch to reverse the motor. Open the switch to return the motor back to its original direction. Refer to Figure 11 on page 22.

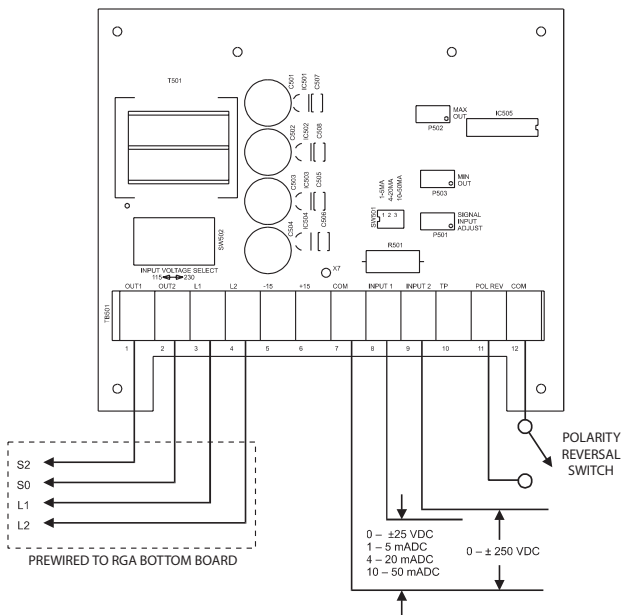

Figure 11. RGA403 Analog Input Signal Connections

Cased Drives



Do not install, rewire, or remove this control with input power applied. Failure to heed this warning may result in fire, explosion, or serious injury. Make sure you read and understand the Safety Precautions on page i before attempting to install this product.

Mounting (NEMA 4X Enclosures)

NEMA 4X cased drives come with two 0.88 inch (22 mm) conduit knockout holes at the bottom of the case. The units may be vertically wall mounted using the four 0.19 inch (5 mm) slotted holes on the attached heat sink. For motor loads less than 5 ADC, the drive may be bench mounted horizontally or operated without mounting.

1. Install the mounting screws.
2. For access to the terminal strip, turn the slotted screw on the front cover counterclockwise until it is free from the case. The right side of the cover is hinged to the case. Pull the slotted screw to open the case.
3. Carefully remove the conduit knockouts by tapping them into the case and twisting them off with pliers.
4. Set the POWER switch to the OFF position before applying the AC line voltage.
5. Install conduit hardware through the 0.88 inch (22 mm) knockout holes. Connect external wiring to the terminal block.
6. Grasp the slotted screw and tilt the front cover back into place. Avoid pinching any wires between the front cover and the case.
7. Turn the slotted screw clockwise until tight to secure the front cover.

Wiring



Do not install, rewire, or remove this control with input power applied. Failure to heed this warning may result in fire, explosion, or serious injury.

Circuit potentials are at 115 or 230 VAC above ground. To prevent the risk of injury or fatality, avoid direct contact with the printed circuit board or with circuit elements.

Do not disconnect any of the motor leads from the drive unless power is removed or the drive is disabled. Opening any one motor lead while the drive is running may destroy the drive.

- Use 18 - 24 AWG wire for logic wiring. Use 14 - 16 AWG wire for AC line and motor wiring.

Line Fusing

Models RGA400-10 and RGA403-10 are preinstalled with 20 amp fuses. Models RGA400-3 and RGA403-3 are preinstalled with 8 amp fuses.

Preinstalled line fuses are rated at or close to maximum horsepower. If the horsepower rating of the motor being used is less than the maximum horsepower rating of the drive, the line fuse may have to be replaced with a lower rated one. Fuses should be rated for 250 VAC or higher and approximately 150% of the maximum armature current. Refer to Table 1 on page 13 for recommended fuse values.

Connections



Do not install, rewire, or remove this control with input power applied. Failure to heed this warning may result in fire, explosion, or serious injury.

Power Input

Connect the AC line power leads to terminals 1 and 2 if using 115 VAC line or to terminals 1 and 3 if using a 230 VAC line. Refer to Figure 12, page 26.

Motor

ACE drives supply motor voltage from A1 and A2 terminals, where A1 is positive with respect to A2 when running in the forward direction. If the motor does not spin in the desired direction, remove power and reverse the A1 and A2 connections.

Connect a DC motor to terminals A1 and A2 as shown in Figure 12 on page 26. Ensure that the motor voltage rating is consistent with the drive's output voltage.

Field Output Connections



The field output is for shunt wound motors only. Do not make any connections to F1 and F2 when using a permanent magnet motor.

See Table 2 on page 16 for field output connections. Use 14 - 16 AWG wire to connect the field output to a shunt wound motor.

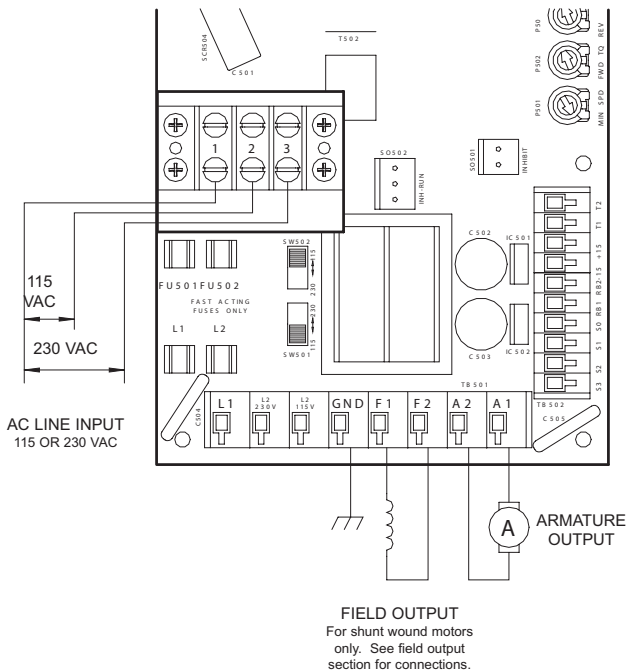

Figure 12. Cased Drive Connections

Analog Input Signal

Instead of using the speed adjust potentiometer on the front cover, the drive may be wired to follow an analog input voltage signal that is isolated from earth ground. See page 20 for details and wiring.

Section 5. Operation



Change voltage switch settings only when the drive is disconnected from AC line voltage. Make sure both switches are set to their correct position. If the switches are improperly set to a lower voltage position, the motor will not run at full voltage and may cause damage to the transformer. If the switches are improperly set to a higher voltage position, the motor will overspeed, which may cause motor damage, or result in bodily injury or loss of life.

Dangerous voltages exist on the drive when it is powered. BE ALERT. High voltages can cause serious or fatal injury. For your safety, use personal protective equipment (PPE) when operating this drive.

If the motor or drive does not perform as described, disconnect the AC line voltage immediately. Refer to the Troubleshooting section, page 57, for further assistance.

Before Applying Power

1. Verify that no foreign conductive material is present on the printed circuit board.
2. Ensure that all switches are properly set.

Select Switches

Input Voltage Select (SW501, SW502)

Set the input voltage select switches SW501 and SW502 to either 115 or 230 to match the AC line voltage. See Figure 13.

Armature Voltage Select (SW503)

Set the armature voltage select switch SW503 to either 90 or 180 to match the maximum armature voltage. See Figure 13.

Feedback Select (SW504)

Set the feedback select switch SW504 to either ARM for armature feedback or TACH for tachogenerator feedback. See Figure 13.

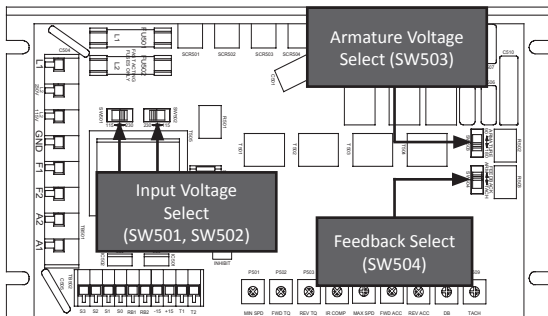

Figure 13. Select Switches

Signal Select (SW501) (RGA403 models only)

Set the signal switch SW501 based on the type of input signal to be used. See Figure 14 for settings and Figure 15 for location.

INPUT SIGNAL LEVEL	DIP SWITCH SETTING		
	1	2	3
VDC	OFF	OFF	OFF
1 - 5 mA	ON	OFF	OFF
4 - 20 mA	OFF	ON	OFF
10 - 50 mA	OFF	OFF	ON

Figure 14. SW501 Settings

Input Voltage Select (SW502) (RGA403 models only)

Set the input voltage select switch SW502 to either 115 or 230 to match the AC line voltage. See Figure 15.

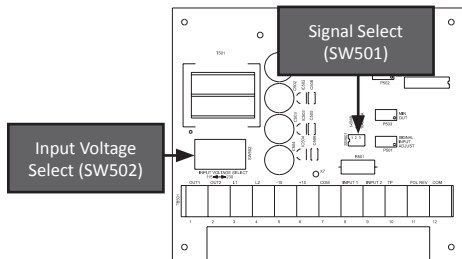

Figure 15. RGA403 Select Switches

Startup

RGA400-3, RGA400-10, RGA403-3, and RGA403-10

1. Turn the speed adjust potentiometer full counterclockwise (CCW) or set the input voltage or current signal to minimum.
2. Apply AC line voltage.
3. Slowly advance the speed adjust potentiometer clockwise (CW) or increase the input voltage or current signal. The motor slowly accelerates as the potentiometer is turned CW or as the input voltage or current signal is increased. Continue until the desired speed is reached.
4. Remove AC line voltage from the drive to coast the motor to a stop.

RGA440-3 and RGA440-10

1. Set the FORWARD/BRAKE/REVERSE switch to the BRAKE position.
2. Turn the speed adjust potentiometer to “0” (full CCW) or set the input voltage signal to minimum.
3. Set the POWER switch to the ON position.
4. Set the FORWARD/BRAKE/REVERSE switch to the desired direction of rotation.
5. Slowly advance the speed adjust potentiometer clockwise (CW) or increase the input voltage signal. The motor slowly accelerates as the potentiometer is turned CW or as the input voltage signal is increased. Continue until the desired speed is reached.
6. To brake the motor to a stop, set the FORWARD/BRAKE/REVERSE switch to the BRAKE position. To coast the motor to a stop, set the POWER switch to the “O” (OFF) position.
7. To reverse direction, set the FORWARD/BRAKE/REVERSE switch to the desired direction.
8. Set the POWER switch to the OFF position.

Starting and Stopping Methods



Regenerative braking, coasting to a stop, or decelerating to minimum speed is recommended for frequent starts and stops. Do not use any of these methods for emergency stopping. They may not stop a drive that is malfunctioning. Removing AC line power (both lines) is the only acceptable method for emergency stopping.

For this reason, ACE strongly recommends installing an emergency stop switch on both AC line inputs (see Figure 9 on page 19).

Frequent starting and stopping can produce high torque. This may cause damage to motors, especially gearmotors that are not properly sized for the application.

Automatic Restart Upon Power Restoration

All drives automatically run to set speed when power is applied if neither the inhibit or regenerative brake are not active and the enable is active.

Line Starting and Stopping

Line starting and stopping (applying and removing AC line voltage) is recommended for infrequent starting and stopping of a drive only. When AC line voltage is applied to the drive, the motor accelerates to the speed set by the speed adjust potentiometer or analog signal. When AC line voltage is removed, the motor coasts to a stop.

Regenerative Brake to Zero Speed (INHIBIT Terminals)

Short the INHIBIT terminals to regeneratively brake the motor to zero speed (see Figure 16). The inhibit bypasses both the MIN SPD trim pot and the deceleration circuit. Open the INHIBIT terminals to accelerate the motor to set speed.

Twist inhibit wires and separate them from power-carrying wires or sources of electrical noise. Use shielded cable if the inhibit wires are longer than 18 inches (46 cm). If shielded cable is used, ground only one end of the shield to earth ground. Do not ground both ends of the shield.

ACE offers two accessory plug harnesses for connecting to the INHIBIT terminals: part number KTW-0001 [plug with 18 in. (46 cm) leads]; and part number KTW-0002 [plug with 36 in. (91 cm) leads].

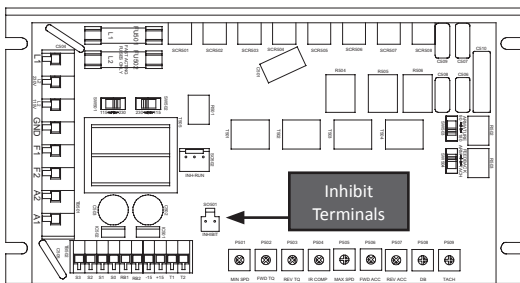

Figure 16. Inhibit Terminals

Regenerative Decel to Zero Speed (RB1 and RB2 Terminals)

Short the RB1 and RB2 terminals to regeneratively brake the motor to zero speed. See Figure 9 on page 17. The RB1 and RB2 circuit follows the deceleration rate set by the FWD ACC and REV ACC trim pots. Open the RB1 and RB2 terminals to accelerate the motor to set speed.

Regenerative Decel to Minimum Speed

The switch shown in Figure 17 may be used to decelerate a motor to a minimum speed. Closing the switch between S0 and S2 decelerates the motor from set speed to a minimum speed determined by the MIN SPD trim pot setting. If the MIN SPD trim pot is set full CCW, the motor decelerates to zero speed. The REV ACC or FWD ACC trim pot setting determines the rate at which the drive decelerates, depending on the direction of deceleration. By opening the switch, the motor accelerates to set speed.

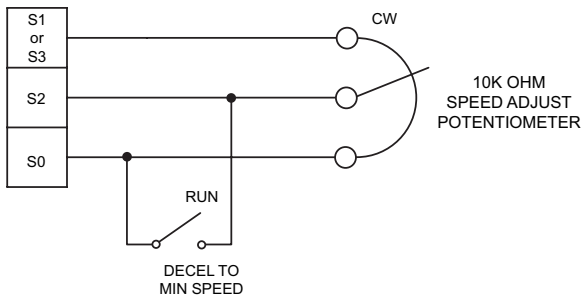

Figure 17. Run/Decelerate to Minimum Speed Switch

Coast to Zero Speed (INHIBIT-RUN)

To coast the motor to a stop without removing power to the drive, jumper INHIBIT-RUN terminals 1 and 2. To restart the motor, jumper INHIBIT-RUN terminals 2 and 3. A single-pole, double-throw switch may be used as a COAST/RUN switch. **Each drive is assembled with INHIBIT-RUN terminals 2 and 3 jumpered. These terminals must be connected for the motor to run.** See Figure 18.

ACE offers an accessory plug harness for connecting to the INHIBIT-RUN terminals: part number KTW-0004 [plug with 18 in. (46 cm) leads].

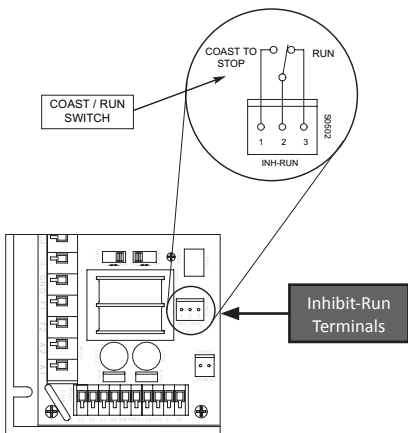

Figure 18. Inhibit-Run Terminal Location and Run/Coast Switch

Section 6. Calibration



Dangerous voltages exist on the drive when it is powered. When possible, disconnect the voltage input from the drive before adjusting the trim pots. If the trim pots must be adjusted with power applied, use insulated tools and the appropriate personal protection equipment. **BE ALERT.** High voltages can cause serious or fatal injury.

RGA series drives have user-adjustable trim pots. Each drive is factory calibrated to its maximum current rating. Readjust the calibration trim pot settings to accommodate lower current rated motors.

All adjustments increase with CW rotation and decrease with CCW rotation. Use a non-metallic screwdriver for calibration. Each trim pot is identified on the printed circuit board.

Minimum Speed (MIN SPD)

The MIN SPD setting determines the minimum motor speed in unidirectional operation when the speed adjust potentiometer is set for minimum speed.

To calibrate the MIN SPD:

1. Set the speed adjust potentiometer or input voltage signal for minimum speed.
2. Adjust MIN SPD until the desired minimum speed is reached or is just at the threshold of rotation.

Maximum Speed (MAX SPD)

The MAX SPD setting determines the maximum motor speed in the forward and reverse direction when the speed adjust potentiometer or input voltage signal is set for maximum speed.

To calibrate MAX SPD:

1. Set the speed adjust potentiometer or input voltage signal for maximum speed.
2. Adjust MAX SPD until the desired maximum speed is reached.

Note: Check the MIN SPD and MAX SPD adjustments after recalibrating to verify that the motor runs at the desired minimum and maximum speed.

Note: If using models RGA403-3 or RGA403-10, the MIN OUT, MAX OUT, and SIGNAL INPUT ADJ trim pots located on the top board must be calibrated first. See page 46 for calibration of those trim pots.

Forward Torque (FWD TQ)



FWD TQ should be set to 150% of motor nameplate current rating. Continuous operation beyond this rating may damage the motor. If you intend to operate beyond the rating, contact your ACE representative for assistance.

The FWD TQ setting determines the maximum torque for accelerating and driving the motor in the forward direction. It also sets the maximum torque for decelerating the motor in the reverse direction. To calibrate FWD TQ, refer to the recommended FWD TQ settings in Figure 19 (page 42) or use the following procedure:

1. With the power disconnected from the drive, connect a DC ammeter in series with the armature.
2. Set the FWD TQ trim pot to minimum (full CCW).
3. Set the speed adjust potentiometer (full CW) or input voltage or current signal to maximum speed.
4. Carefully lock the motor armature. Be sure that the motor is firmly mounted.
5. Apply line power. The motor should be stopped.
6. Slowly adjust the FWD TQ trim pot CW until the armature current is 150% of motor rated armature current.
7. Set the speed adjust potentiometer CCW or decrease the input voltage or current signal to minimum speed.
8. Remove line power.
9. Remove the stall from the motor.
10. Remove the ammeter in series with the motor armature if it is no longer needed.

Reverse Torque (REV TQ)



REV TQ should be set to 150% of motor nameplate current rating. Continuous operation beyond this rating may damage the motor. If you intend to operate beyond the rating, contact your ACE representative for assistance.

The REV TQ setting determines the maximum torque for accelerating the motor in the reverse direction. It also sets the maximum torque for decelerating the motor in the reverse direction. To calibrate REV TQ, refer to the recommended REV TQ settings in Figure 19 (page 42) or use the following procedure:

1. With the power disconnected from the drive, connect a DC ammeter in series with the armature.
2. Set the REV TQ trim pot to minimum (full CCW).
3. Set the speed adjust potentiometer or input voltage or current signal to maximum speed.
4. Carefully lock the motor armature. Be sure that the motor is firmly mounted.
5. Apply line power. The motor should be stopped.
6. Slowly adjust the REV TQ trim pot CW until the armature current is 150% of motor rated armature current.
7. Set the speed adjust potentiometer CCW or decrease the input voltage or current signal to minimum speed.
8. Remove line power.
9. Remove the stall from the motor.
10. Remove the ammeter in series with the motor armature if it is no longer needed.

IR Compensation (IR COMP)



















The IR COMP setting determines the degree to which motor speed is held constant as the motor load changes.

Use the following procedure to recalibrate the IR COMP setting:

1. Set the IR COMP trim pot to minimum (full CCW).
2. Increase the speed adjust potentiometer or input voltage or current signal until the motor runs at midspeed without load (for example, 900 RPM for an 1800 RPM motor). A handheld tachometer may be used to measure motor speed.
3. Load the motor armature to its full load armature current rating. The motor should slow down.
4. While keeping the load on the motor, rotate the IR COMP trim pot until the motor runs at the speed measured in step 2. If the motor oscillates (overcompensation), the IR COMP trim pot may be set too high (CW). Turn the IR COMP trim pot CCW to stabilize the motor.
5. Unload the motor.

See Figure 19 on page 42 for recommended IR COMP settings.

MODELS RGA400-3, RGA403-3, RGA440-3

			1/8 HP 90 VDC 1.25 AMPS				1/4 HP 180 VDC 1.25 AMPS
FWD TQ	REV TQ	IR COMP		FWD TQ	REV TQ	IR COMP	
			1/10 HP 90 VDC 1.00 AMP				1/5 HP 180 VDC 1.00 AMP
FWD TQ	REV TQ	IR COMP		FWD TQ	REV TQ	IR COMP	
			1/20 HP 90 VDC 0.50 AMPS				1/10 HP 180 VDC 0.50 AMPS
FWD TQ	REV TQ	IR COMP		FWD TQ	REV TQ	IR COMP	

MODELS RGA400-10, RGA403-10, RGA440-10































			1 HP 90 VDC 10.0 AMPS				2 HP 180 VDC 10.0 AMPS
FWD TQ	REV TQ	IR COMP		FWD TQ	REV TQ	IR COMP	
			3/4 HP 90 VDC 7.50 AMPS				1 1/2 HP 180 VDC 7.50 AMPS
FWD TQ	REV TQ	IR COMP		FWD TQ	REV TQ	IR COMP	
			1/2 HP 90 VDC 5.00 AMPS				1 HP 180 VDC 5.00 AMPS
FWD TQ	REV TQ	IR COMP		FWD TQ	REV TQ	IR COMP	
			1/3 HP 90 VDC 3.33 AMPS				3/4 HP 180 VDC 3.75 AMPS
FWD TQ	REV TQ	IR COMP		FWD TQ	REV TQ	IR COMP	
			1/4 HP 90 VDC 2.50 AMPS				1/2 HP 180 VDC 2.50 AMPS
FWD TQ	REV TQ	IR COMP		FWD TQ	REV TQ	IR COMP	

Figure 19. Recommended FWD TQ, REV TQ, and IR COMP Settings
(actual settings may vary with each application)

Forward Acceleration (FWD ACC)

The FWD ACC setting determines the time the motor takes to ramp to a higher speed in the forward direction or to a lower speed in the reverse direction. See Specifications on page 2 for approximate acceleration times. ACCEL is factory set for the fastest acceleration time (full CCW).

Turn the FWD ACC trim pot CW to increase the forward acceleration time and CCW to decrease the forward acceleration time.

Reverse Acceleration (REV ACC)

The REV ACC setting determines the time the motor takes to ramp to a lower speed in the forward direction or to a higher speed in the reverse direction. See Specifications on page 2 for approximate acceleration times. REV ACC is factory set for the fastest acceleration time (full CCW).

Turn the REV ACC trim pot CW to increase the reverse acceleration time and CCW to decrease the reverse acceleration time

Deadband (DB)

The DB setting determines the time that will elapse between the application of current in one direction before current is applied in the opposite direction.

The DB affects the resistance that a motor has to changes in the shaft position at zero speed. It does this by applying an AC voltage to the motor armature.

The deadband is factory calibrated to approximately 3/4 of a turn clockwise from the full counter-clockwise position for 60 Hz AC line operation. Recalibrate the trim pot to approximately a 1/4 of a turn clockwise from the full counter-clockwise position for 50 Hz AC line operation. If you hear motor noise (humming), the deadband might be set too high. Turn the DB trim pot CCW until the motor noise ceases.

Tachogenerator (TACH)



Calibrate the TACH setting only when a tachogenerator is used.

The TACH setting, like IR COMP setting, determines the degree to which motor speed is held constant as the motor load changes. To calibrate the TACH trim pot:

1. Set the IR COMP trim pot to full CW.
2. Connect the tachogenerator to T1 and T2. The polarity is positive (+) for T1 and negative (-) for T2 when the motor is running in the forward direction.
3. Set the feedback select switch SW504 to ARM for armature feedback.
4. Set the speed adjust potentiometer or input voltage or current signal to maximum speed. Measure the armature voltage across A1 and A2 using a voltmeter.
5. Set the speed adjust potentiometer or input voltage or current signal to zero speed.
6. Set SW504 to TACH for tachogenerator feedback.
7. Set the TACH trim pot to full CW.
8. Set the speed adjust potentiometer or input voltage or current signal to maximum speed.
9. Adjust the TACH trim pot until the armature voltage is the same value as the voltage measured in step 3.

Check that the TACH is properly calibrated. The motor should run at the same set speed when SW504 is set to either armature or tachogenerator feedback.

Minimum Speed (MIN OUT), Maximum Speed (MAX OUT) & Signal Input Adjust (RG403 models only)

The following minimum and maximum values should be known.

S_{min} - Minimum analog signal input.

S_{max} - Maximum analog signal input.

1. Switch the SW501 DIP switches to the following positions based on the input signal being used.

Input Signal Level	DIP SWITCH SETTING		
	1	2	3
Voltage	OFF	OFF	OFF
1-5 mA	ON	OFF	OFF
4-20 mA	OFF	ON	OFF
10-50 mA	OFF	OFF	ON

Figure 20. DIP Switch SW501 Settings

2. Connect (but do not apply) the analog input signal as follows.
 - Connect the signal negative (-) to terminal 7 (COM).
 - For a current signal or a 0 to ± 25 VDC voltage signal, connect the signal positive (+) to terminal 8 (INPUT 1).
 - For a 0 - ± 250 VDC voltage signal, connect the signal positive (+) to terminal 9 (INPUT 2).
3. Apply both the AC line and the analog input signal.

4. Set the analog input signal to minimum (ie 4 mA or 0 VDC).
5. Adjust the MIN OUT (P503) trim pot so that the voltage between terminals 1 (OUT1) and 2 (OUT2) of the top board is 0 VDC.
6. Set the analog input signal to maximum (ie 20 mA or 10 VDC).
7. Calculate the test point voltage, V_{tp} :

$$V_{tp} = \frac{0.5 * \text{Maximum Analog Signal}}{\text{Maximum Analog Signal} - \text{Minimum Analog Signal}}$$

8. Adjust the SIGNAL INPUT ADJ (P501) trim pot so that the voltage from terminals 7 (COM) and 10 (TP) is V_{tp} .
9. Adjust the MAX OUT (P502) trim pot so that the output voltage is 10 VDC.
10. Repeat steps 4, 5, 6, 8, and 9. Use the same voltage/current values that you previously used.

Section 7. Application Notes

FWD-REV and FWD-STOP-REV Switch

Use a single-pole, two-position switch with a single speed adjust potentiometer for a direction switch as shown in Figure 21. If a STOP position is desired, use a single-pole, three-position switch as shown in Figure 22. The STOP deceleration rate is set by the FWD ACC and REV ACC trim pots.

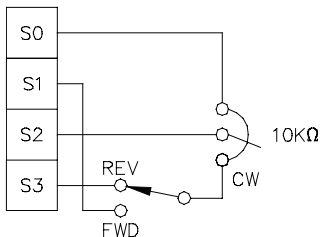

Figure 21. Forward-Reverse Switch

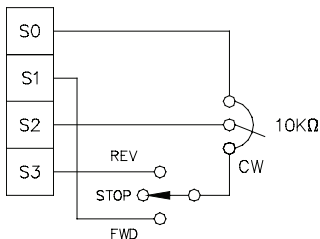

Figure 22. Forward-Stop-Reverse Switch

Multiple Fixed Speeds

Replace the speed adjust potentiometer with series resistors with a total series resistance of 10K ohms (Figure 23). Add a single pole, multi-position switch with the correct number of positions for the desired number of fixed speeds.

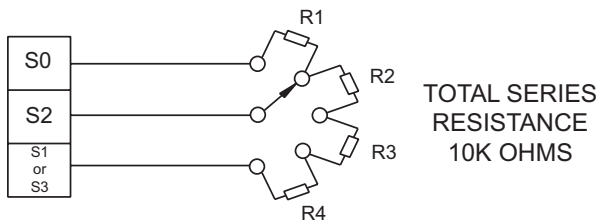

Figure 23. Multiple Fixed Speeds

Independent Adjustable Speeds

Replace the speed adjust potentiometer with a single pole, multi-position switch, and two or more potentiometers in parallel, with a total parallel resistance of 10K ohms. Figure 25 shows the connection of two independent speed adjust potentiometers that can be mounted at two separate operating stations.

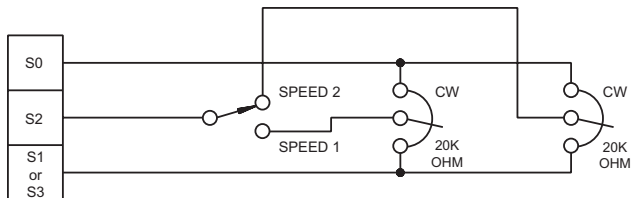

Figure 25. Independent Adjustable Speeds

Independent Forward and Reverse Speeds

Connect two speed adjust potentiometers and a single-pole, two-position switch as shown in Figure 26 to select between independent forward and reverse speeds. If a STOP position is desired, use a single-pole, three-position switch as shown in Figure 27.

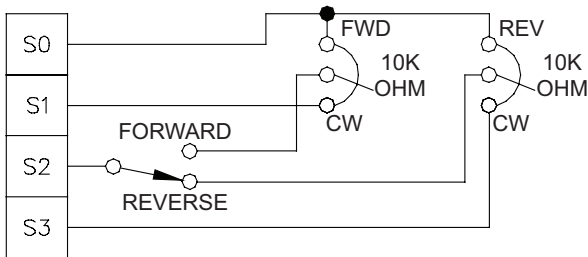

Figure 26. Independent Forward and Reverse Speeds with a FWD-REV Switch

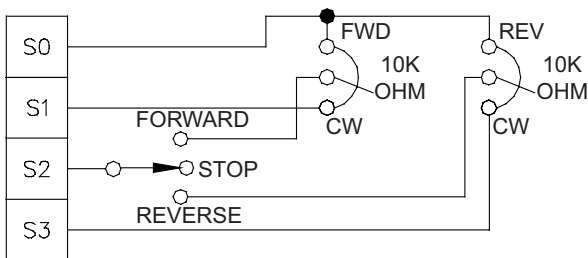

Figure 27. Independent Forward and Reverse Speeds with a FWD-STOP-REV Switch

FWD-REV Switch with End-of-Travel Limit Switches

Use a single-pole, two-position switch with a single speed adjust potentiometer for a direction switch as shown in Figure 28. Wire a normally closed limit switch in series with S1 (forward limit) and another (reverse limit) in series with S3.

If automatic cycling with limit switches is desired, use American Control Electronics switching logic board, model number LSL100-1.

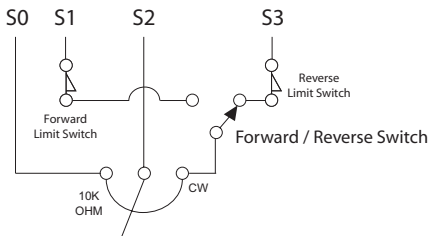

Figure 28. FWD-REV Switch with End-of-Travel Limit Switches

RUN/JOG Switch - Inhibit Connection

Use a single pole, two position switch for the RUN/JOG switch, and a normally closed momentary pushbutton for the JOG pushbutton.

Connect the RUN/JOG switch and JOG pushbutton to the inhibit plug as shown in Figure 29. The motor coasts to a stop when the RUN/JOG switch is set to JOG. Press the JOG pushbutton to jog the motor. Return the RUN/JOG switch to RUN for normal operation.

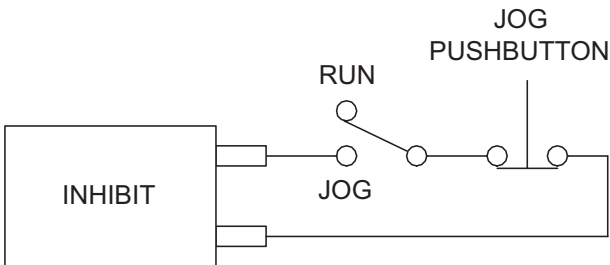

Figure 29. RUN/JOG Switch Option #1 - Connection to Inhibit Plug

RUN/JOG Switch - Potentiometer Connection

Connect the RUN/JOG switch and the JOG pushbutton as shown in the Figure 30. When the RUN/JOG switch is set to JOG, the motor decelerates to minimum speed (minimum speed is determined by the MIN SPD trimpot setting). Press the JOG pushbutton to jog the motor. Return the RUN/JOG switch to RUN for normal operation.

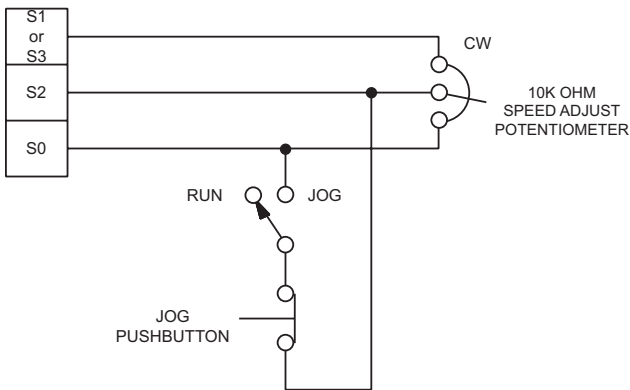

Figure 30. RUN/JOG Switch Option #2 -
Connection to Speed Adjust Potentiometer

Leader-Follower Application

In this application, use a ISO101-1 to monitor the speed of the leader motor (Figure 31). The ISO101-1 isolates the leader motor from the follower drive, and outputs a voltage proportional to the leader motor armature voltage. The follower drive uses this voltage reference to set the speed of the follower motor. An optional ratio potentiometer may be used to scale the ISO101-1 output voltage.

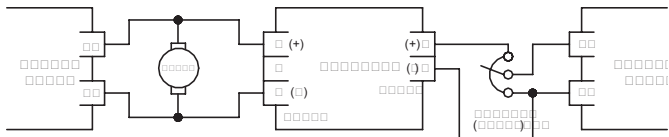

Figure 31. Leader-Follower Application

Section 8. Troubleshooting



Dangerous voltages exist on the drive when it is powered. When possible, disconnect the drive while troubleshooting. High voltages can cause serious or fatal injury.

Before Troubleshooting

Perform the following steps before starting any procedure in this section:

1. Disconnect AC line voltage from the drive.
2. Check the drive closely for damaged components.
3. Check that no conductive or other foreign material has become lodged on the printed circuit board.
4. Verify that every connection is correct and in good condition.
5. Verify that there are no short circuits or grounded connections.
6. Check that the switch settings are correctly set.
7. Check that the drive's rated armature and field outputs are consistent with the motor ratings.

For additional assistance, contact your local AMERICAN CONTROL ELECTRONICS distributor, or the factory direct:

1-800-646-2745 or FAX: 1-815-624-6960

PROBLEM	POSSIBLE CAUSE	SUGGESTED SOLUTIONS
Line fuse blows.	1. Line fuse is the wrong size.	1. Check that the line fuse is correct for the motor size.
	2. Motor cable or armature is shorted to ground.	2. Check motor cable and armature shorts.
	3. Nuisance tripping caused by a combination of ambient conditions and high-current spikes (i.e. reversing).	3. Add a blower to cool the drive components; decrease TORQUE settings, or resize motor and drive for actual load demand, or check for incorrectly aligned mechanical components or "jams". See page 44 for information on adjusting the TORQUE trimpot.
Line fuse does not blow, but the motor does not run.	1. Speed adjust potentiometer or speed reference voltage is set to zero speed.	1. Increase the speed adjust potentiometer setting or speed reference voltage.
	2. INHIBIT mode is active.	2. Remove the short from the INHIBIT terminals or add a short to INHIBIT terminals if INHIBIT mode is set to INVERTED.
	3. S2 is shorted to S1.	3. Remove the short.
	4. Drive is in current limit.	4. Verify that the motor is not jammed. Increase TORQUE setting if set too low. See page 44.
	5. Drive is not receiving AC line voltage.	5. Apply AC line voltage to L1 and L2.
	6. Motor is not connected.	6. Connect the motor to A1 and A2.

PROBLEM	POSSIBLE CAUSE	SUGGESTED SOLUTIONS
Motor runs in the opposite direction (non-reversing drives)	1. Motor connections to A1 and A2 are reversed.	1. Reverse connections to A1 and A2.
Motor runs too fast.	1. MAX SPD and MIN SPD are set too high.	1. Calibrate MAX SPD and MIN SPD. See page 43.
	2. Motor field connections are loose (shunt wound motors only).	2. Check motor field connections.
Motor will not reach the desired speed.	1. MAX SPD setting is too low.	1. Increase MAX SPD setting. See page 43.
	2. IR COMP setting is too low.	2. Increase IR COMP setting. See page 44.
	3. TORQUE setting is too low.	3. Increase TORQUE setting. See page 44.
	4. Motor is overloaded.	4. Check motor load. Resize the motor and drive if necessary.
Motor pulsates or surges under load.	1. IR COMP is set too high.	1. Adjust the IR COMP setting slightly CCW until the motor speed stabilizes. See page 45.
	2. Motor bouncing in and out of current limit.	2. Make sure the motor is not undersized for load; adjust FWD TQ or REV TQ trim pot CW. See page 39 or 40.

Section 9. Block Diagrams

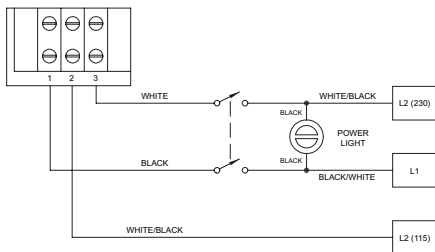
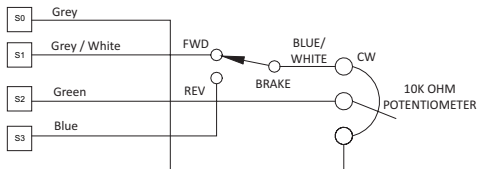

Figure 32. Prewired Connections for RGA440

Section 10. Accessories & Replacement Parts

Displays

Closed Loop.....	CLD100-1
Open Loop.....	OLD100-1

Heat sinks

Chassis.....	HSK-0004
--------------	----------

Kits

Potentiometer & Connector

10K Pot, Insulating Washer.....	KTP-0001
---------------------------------	----------

Fuse

2 1.5 Amp 250 V 3AG Fast-blow Glass Fuses.....	KTF-0001
2 3 Amp 250 V 3AG Fast-blow Glass Fuses.....	KTF-0002
2 5 Amp 250 V 3AG Fast-blow Glass Fuses.....	KTF-0003
2 8 Amp 250 V 3AG Fast-blow Glass Fuses.....	KTF-0004
2 10 Amp 250 V 3AB Normal-blow Ceramic Fuses.....	KTF-0005
2 15 Amp 250 V 3AB Normal-blow Ceramic Fuses.....	KTF-0006

Wiring

Inhibit Plug (18 in. leads).....	KTW-0001
Inhibit Plug (36 in. leads).....	KTW-0002

Logic Cards

Current Monitoring

5 Amps.....	CMC100-5
20 Amps.....	CMC100-20

Isolation

RGA403 Series Top Isolation Board.....	ISO401-1
--	----------

Notes

Unconditional Warranty

A. Warranty

American Control Electronics, referred to as “the Corporation” warrants that its products will be free from defects in workmanship and material for twelve (12) months or 3000 hours, whichever comes first, from date of manufacture thereof. Within this warranty period, the Corporation will repair or replace, at its sole discretion, such products that are returned to American Control Electronics, 14300 De La Tour Drive, South Beloit, Illinois 61080 USA.

This warranty applies only to standard catalog products, and does not apply to specials. Any returns of special controls will be evaluated on a case-by-case basis. The Corporation is not responsible for removal, installation, or any other incidental expenses incurred in shipping the product to and from the repair point.

B. Disclaimer

The provisions of Paragraph A are the Corporation’s sole obligation and exclude all other warranties of merchantability for use, expressed or implied. The Corporation further disclaims any responsibility whatsoever to the customer or to any other person for injury to the person or damage or loss of property of value caused by any product that has been subject to misuse, negligence, or accident, or misapplied or modified by unauthorized persons or improperly installed.

C. Limitations of Liability

In the event of any claim for breach of any of the Corporation’s obligations, whether expressed or implied, and particularly of any other claim or breach of warranty contained in Paragraph A, or of any other warranties, expressed or implied, or claim of liability that might, despite Paragraph B, be decided against the Corporation by lawful authority, the Corporation shall under no circumstances be liable for any consequential damages, losses, or expenses arising in connection with the use of, or inability to use, the Corporation’s product for any purpose whatsoever.

An adjustment made under warranty does not void the warranty, nor does it imply an extension of the original 12-month warranty period. Products serviced and/or parts replaced on a no-charge basis during the warranty period carry the unexpired portion of the original warranty only.

If for any reason any of the foregoing provisions shall be ineffective, the Corporation’s liability for damages arising out of its manufacture or sale of equipment, or use thereof, whether such liability is based on warranty, contract, negligence, strict liability in tort, or otherwise, shall not in any event exceed the full purchase price of such equipment.

Any action against the Corporation based upon any liability or obligation arising hereunder or under any law applicable to the sale of equipment or the use thereof, must be commenced within one year after the cause of such action arises.



www.americancontrolelectronics.com

• 14300 DE LA TOUR DRIVE • SOUTH BELOIT, IL 61080 •
• (815) 624-6915 • (815) 624-6965 fax •

Document Number - MAN-0010, Rev 0 - March 2012

© 2011 AMERICAN CONTROL ELECTRONICS®